



ST Series

L87

Applications	Outdoor - Neighborhoods, Parking Lots, Main and Sub roads, Gas Stations, Parks
Mounting	Pole
THD	< 10
Power Factor	0.98
Housing	Die cast aluminum
Diffuser	PC Lens
Mounting adjustment	-10 to +10
Internal Protection	IP 66
Impact Strength	IK 10
Weight	4.5 - 5.8 Kg
Efficacy	140 Lumens / Watt
Working Temp (ta)	60°C
Warranty	5 Years
Life Time	100,000 Hours
CRI	> 80
Certification	SASO 2902 UL Listed LM79, ISTMT, TM21 Photobiological



Other Options	Dimming 0-10V Photocell Slip Fitter bracket Trunion mount bracket Yoke mount bracket
----------------------	--

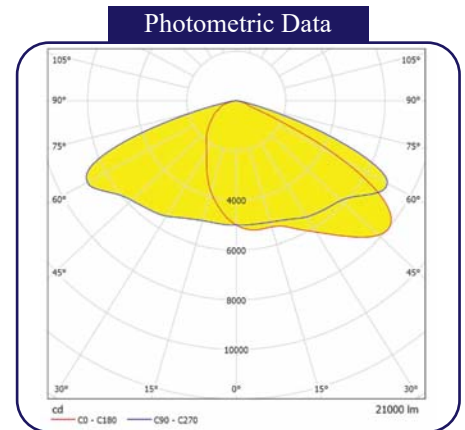

Drawing

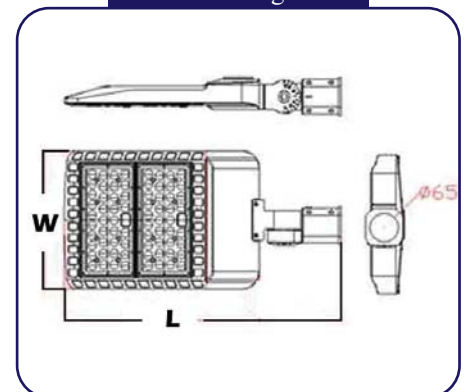

Model	Power	Size (L x W x H)	Lumen	Voltage	CCT	Beam Angle
NLC L87	50W	471 x 300 x 82 mm	7000 LM	220-240V/50/60Hz 110-277V/ 50/60Hz	3000K	60° 90° 155 x 80° 165 x 115° 90 x 120°
	80W		11200 LM			
	100W	554 x 300 x 82 mm	14000 LM			
	150W		21000 LM			
	200W	652 x 300 x 82 mm	28000 LM			
	240W		33600 LM			
	265W		37100 LM			
	300W		42000 LM			

Environment friendly product that is free of any hazardous materials

