



SM Series

SM-04

Applications	Indoor - Office, Clinic, Class room, Corridor, Kitchen, Retail shop, Stair case, Bedroom
Mounting	Surface
THD	< 10
Power Factor	0.95
Housing	Polycarbonate
Diffuser	PMMA
Internal Protection	IP 65
Impact Strength	IK 10
Weight	0.9 - 1.3 Kg
Efficacy	100 Lumens / Watt
Working Temp (ta)	50°C
Warranty	5 Years
Life Time	50,000 Hours
CRI	> 80
Certification	SASO 2902 LM79, ISTMT, TM21 Photobiological



Other Options	Emergency Backup - 3 Hr Dimming 0-10V Dali Interface Wall Mounted
----------------------	--

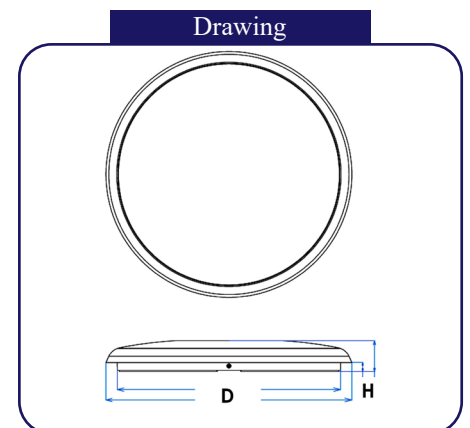
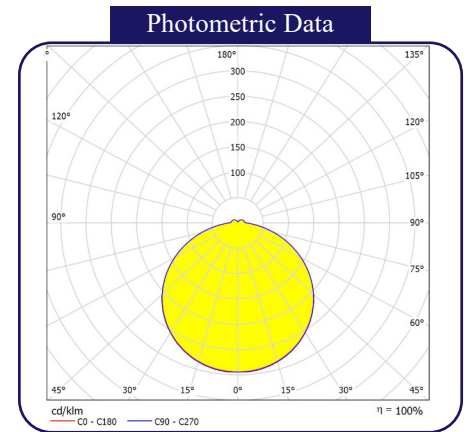

Model	Power	Size (D x H)	Lumen	Voltage	CCT	Beam Angle
NLC SM-04	15W	Φ220x 50 mm	1500LM	220-240V/50/60Hz 110-277V/ 50/60Hz	3000K 4000K 6000K	120°
	24W	Φ280 x 50 mm	2400 LM			
	30W	Φ330 x 50 mm	3000 LM			
	40W	Φ385 x 50 mm	4000 LM			

Environment friendly product that is free of any hazardous materials

