

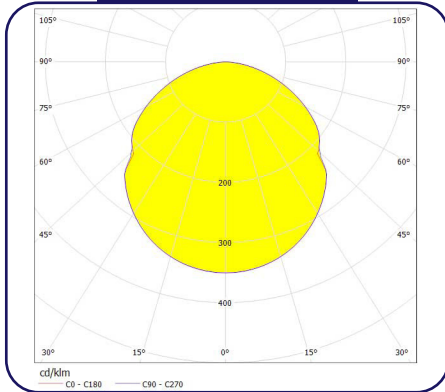

SM Series

SM-03

Photometric Data



Drawing

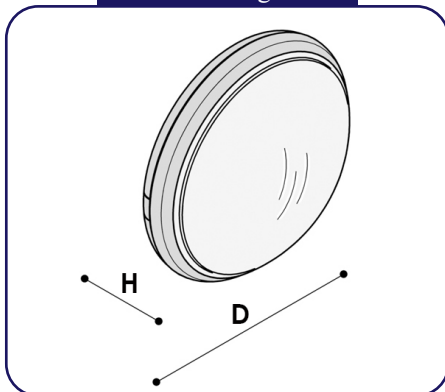

Applications

Indoor / Outdoor - Corridor, Kitchen, Retail shop, Stair case, Canopy, Bulkhead

Mounting

Surface

THD

< 10

Power Factor

0.95

Housing

Reinforced Polycarbonate

Diffuser

PMMA Opal

Internal Protection

IP 65

Impact Strength

IK 08

Weight

1.4 Kg

Efficacy

100 Lumens / Watt

Working Temp (ta)

55°C

Warranty

5 Years

Life Time

72,000 Hours

CRI

> 80

Certification

SASO 2902

UL Listed

LM79, ISTMT, TM21

Photobiological



Other Options

Emergency Backup - 3 Hr

Dimming 0-10V

Dali Interface

Wall Mounted



Model	Power	Size (D x H)	Lumen	Voltage	CCT	Beam Angle
NLC SM-03	15W	260 x 102 mm	1500 LM	220-240V/50/60Hz 110-277V/ 50/60Hz	3000K	120°
	22W		2200 LM		4000K	
	30W		3000 LM		6000K	

