

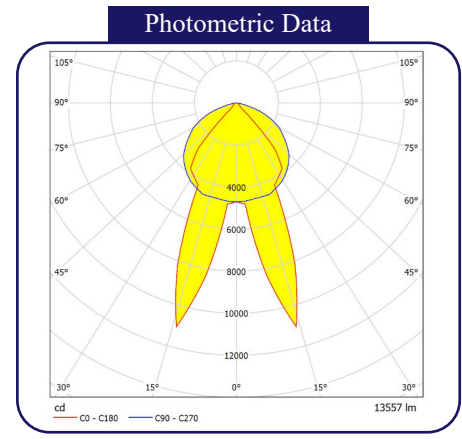

EX Series / **LHFL**

Applications	Parking lots, Warehouses, Factories, Mining/Heavy industry, Sporting Complexes, Retails, Exhibition halls
Mounting	Wall
THD	< 10
Power Factor	0.95
Housing	Aluminium with epoxy finish
Diffuser	Tempered glass
Internal Protection	IP 66
Impact Strength	IK 10
Efficacy	100 Lumens / Watt
Working Temp (ta)	55°C
Warranty	5 Years
Life Time	70,000 Hours
CRI	> 80
Certification	SASO 2902 LM79, ISTMT, TM21 Photobiological NEMA 4X UL 844 Hazardous Locations UL 1598A Marine Outside Type UL 1598 Wet Locations UL 8750 LED Safety Class I, Division 2, Groups A, B, C & D - T5 Class II, Divisions 1 & 2, Groups E, F & G - T4A Class III Zone 2, Groups IIA, IIB & IIC 65°C Ambient Temperature (Class I, Division 2) ABS Type Approved



Other Options	Emergency Backup - 3 Hr	
	Dimming 0-10V	
	Dali Interface	
	Guard & Visor	

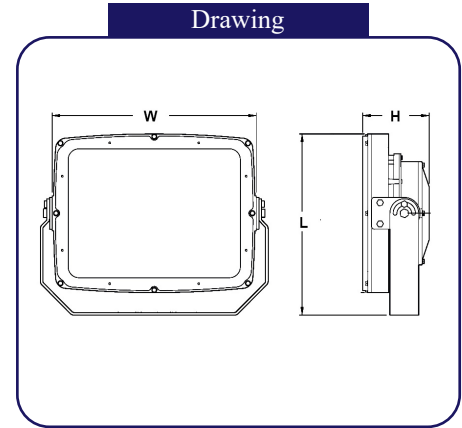

Model	Power	Size (L x W x H)	Lumen	Voltage	CCT	Beam Angle
NLC LHFL	07=70W	435 x 495 x 161 mm	7420 LM	U=120-277V/60Hz N=347/480V/60Hz	3000K	90°
	15=130W		13780 LM		4000K	
	200=188W		19928 LM		6000K	

Environment friendly product that is free of any hazardous materials

