



ST Series / **L88**

Applications Outdoor - Neighborhoods, Parking Lots, Main and Sub roads, Gas Stations, Parks

Mounting	Slip fitter - Pole
THD	< 10
Power Factor	0.95
Housing	Die cast aluminum
Diffuser	Tempered glass
Internal Protection	IP 66
Impact Strength	IK 09
Weight	4.4 - 6.8 Kg
Efficacy	150 Lumens / Watt
Working Temp (ta)	55°C
Warranty	5 Years
Life Time	100,000 Hours
CRI	> 80

Certification SASO 2902
LM79, ISTMT, TM21
Photobiological



Other Options Dimming 0-10V
Photocell
High efficacy - 170LM/W

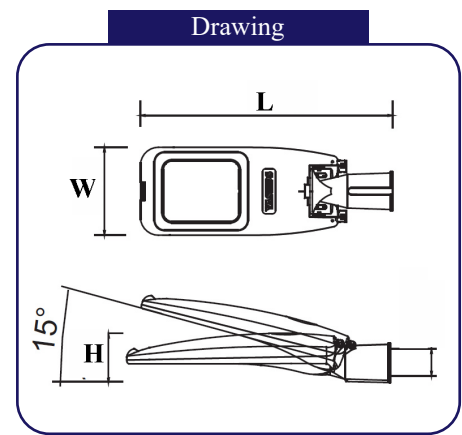
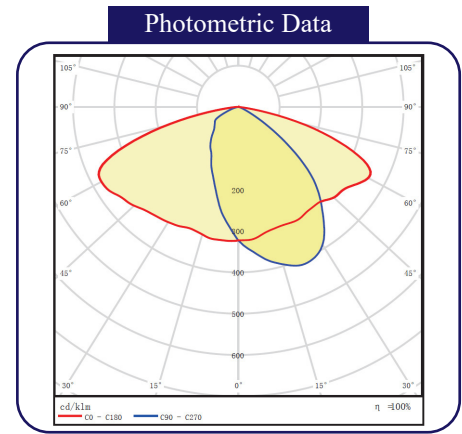

Model	Power	Size (L x W x H)	Lumen	Voltage	CCT	Beam Angle
NLC L88	40W	558 x 195 x 108 mm	6000 LM	220-240V/50/60Hz 110-277V/ 50/60Hz	3000K 4000K 5700K	120°
	60W		9000 LM			
	80W	612 x 262 x 110 mm	12000 LM			
	100W		15000 LM			
	120W	677 x 280 x 116 mm	18000 LM			
	150W		23250 LM			

Environment friendly product that is free of any hazardous materials

