









**FL Series** / **L65**

<b>Applications</b>	Outdoor - Areas, Farms, Building Washers, Parking Area
<b>Mounting</b>	Trunion - Pole / Wall
<b>THD</b>	< 10
<b>Power Factor</b>	0.98
<b>Housing</b>	Die cast aluminum
<b>Diffuser</b>	Tempered glass
<b>Internal Protection</b>	IP 66
<b>Impact Strength</b>	IK 08
<b>Weight</b>	1.4- 4.6 Kg
<b>Efficacy</b>	130 Lumens / Watt
<b>Working Temp (ta)</b>	60°C
<b>Warranty</b>	5 Years
<b>Life Time</b>	72,000 Hours
<b>CRI</b>	> 80
<b>Certification</b>	SASO 2902  UL Listed  LM79, ISTMT, TM21  Photobiological 
<b>Other Options</b>	Dimming 0-10V  Photocell 

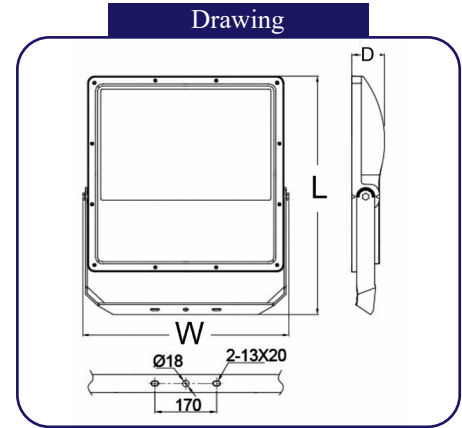
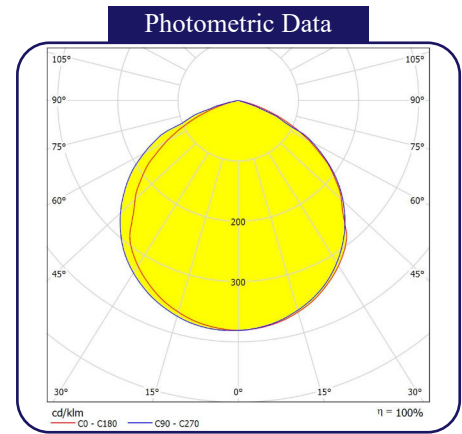

Model	Power	Size (L x W x D)	Lumen	Voltage	CCT	Beam Angle
NLC L65	150W	480 x 475 x 63 mm	19500 LM	220-240V/50/60Hz	3000K	60°
	200W		26000 LM		4000K	
	360W	570 x 660 x 90 mm	46800 LM	110-277V/ 50/60Hz	5700K	90°
	480W		62400 LM			

Environment friendly product that is free of any hazardous materials 