

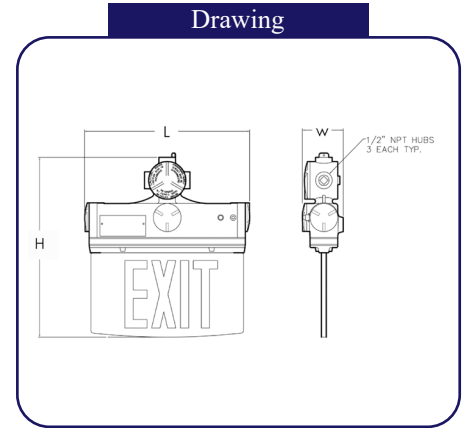

EX Series / **HLEX**

Applications	Parking lots, Warehouses, Factories, Mining/Heavy industry, Sporting Complexes, Retails, Exhibition halls
Mounting	Wall/Pendant or End mount configurations
Sign	acrylic
Source	LED
Housing	A356T6 Aluminum
Emergency Backup	3 Hr
Internal Protection	IP 65
Impact Strength	IK 10
Weight	6Kg
Number of Faces	Single Face or Double Face
Working Temp (ta)	50°C
Warranty	5 Years
Life Time	70,000 Hours
CRI	> 80
Certification	SASO 2902 UL 844 hazardous locations UL 1598A marine outside type UL 1598 wet locations ETL Listed Class I, Division 2, Groups A, B, C and D Class II, Division 2, Groups F and G Class III

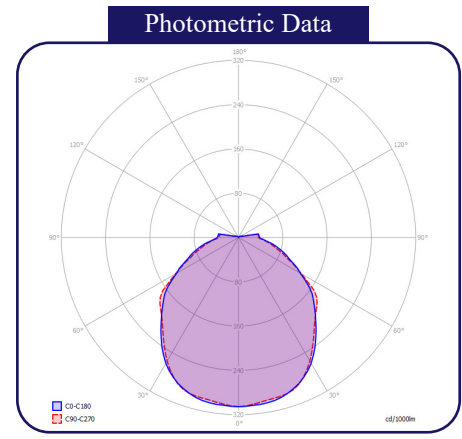

Other Options Customized Text - Sticker
Right & Left Arrow

Model	Size (L x H x W)	No. of Faces	Maximum Input Power	Voltage
NLC HLEX	378 x 406 x 94 mm	1- Single Face	Red No Battery: 1.5 Watts Red With Battery: 2.5 Watts	220-240V/50/60Hz
		2- Double Face	Green No Battery: 2.3 Watts Green With Battery: 3.0 Watts	120-277V/ 50/60Hz

Environment friendly product that is free of any hazardous materials

