





EM Series / **EU900**

| | |
|----------------------------|--|
| Applications | Indoor - Office, Clinic, Class room, Corridor, Kitchen, Retail shop |
| Mounting | Wall |
| Source | LED |
| Wattage | 4.2W |
| Housing | Metal housing and ABS twin spot heads |
| Operating Mode | Non Maintained |
| Emergency Backup | 3 Hr |
| Internal Protection | IP 20 |
| Impact Strength | IK 03 |
| Weight | 5.7 Kg |
| Working Temp (ta) | 50°C |
| Warranty | 5 Years |
| Life Time | 50,000 Hours |
| CRI | > 80 |
| Certification | SASO 2902  UL Listed  |

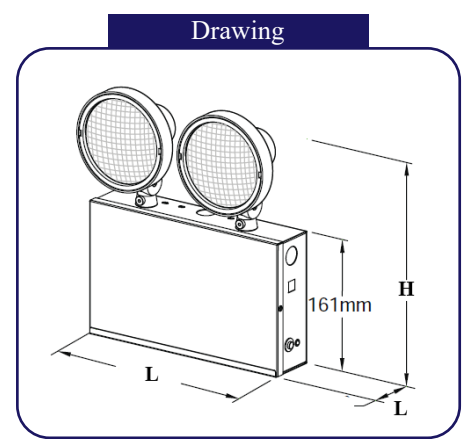
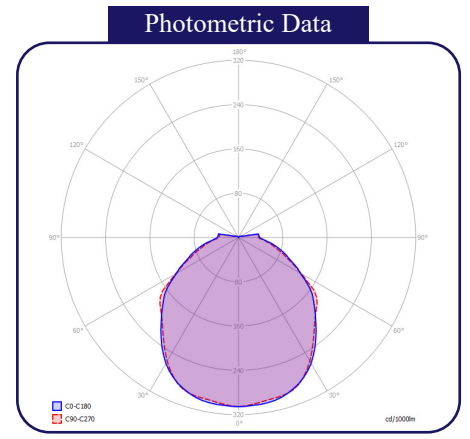

| Model | Power | Size (L x W x H) | Lumen | Voltage |
|-----------|-------|-------------------|--------|--------------------------------------|
| NLC EU900 | 4.2W | 264 x 61 x 312 mm | 420 LM | 220-240V/50/60Hz 120-277V/50/60Hz |

Environment friendly product that is free of any hazardous materials 

