

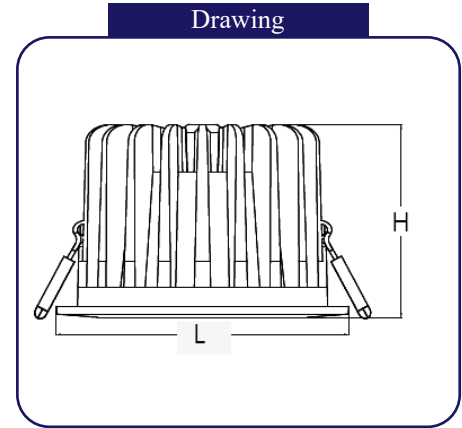

DL Series / **DL-06**

Applications	Indoor - Office, Clinic, Workshop, Corridor, Kitchen, Retail shop, Showroom, Toilet
Mounting	Recessed
THD	< 10
Power Factor	0.95
Housing	Die-cast aluminium
Reflector	Anodized Aluminum
Internal Protection	IP 20
Impact Strength	IK 05
Weight	0.9 - 1.8 Kg
Efficacy	100 Lumens / Watt
Working Temp (ta)	50°C
Warranty	5 Years
Life Time	60,000 Hours
CRI	> 80
Certification	SASO 2902 UL Listed LM79, ISTMT, TM21 Photobiological
Other Options	Emergency Backup - 3 Hr Dimming 0-10V Dali Interface IP 54 Gear Box

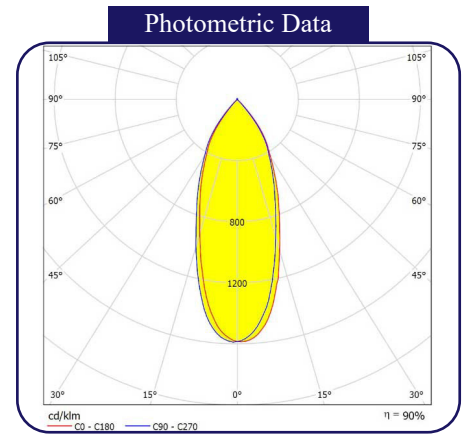

Model	Power	Size (D x H)	Lumen	Voltage	CCT	Beam Angle
NLC DL-06	10W	Φ66 x 60 mm	1000LM	220-240V/50/60Hz	3000K 4000K 6000K	15°
	15W	Φ83 x 72mm	1500LM			24°
	30W	Φ107 x 87 mm	3000LM			38°
	40W	Φ135 x 89 mm	4000LM			60°

Environment friendly product that is free of any hazardous materials

