



DL Series / **DL-02**

Applications	Indoor - Office, Clinic, Class room, Corridor, Kitchen, Retail shop, Showroom, Bedroom
Mounting	Recessed
THD	< 10
Power Factor	0.95
Housing	Die-cast aluminium
Internal Protection	IP 20
Impact Strength	IK 03
Weight	0.4 -0.8 Kg
Efficacy	100 Lumens / Watt
Working Temp (ta)	50°C
Warranty	5 Years
Life Time	72,000 Hours
CRI	> 80
Certification	SASO 2902 UL Listed LM79, ISTMT, TM21 Photobiological
Other Options	Emergency Backup - 3 Hr Dimming 0-10V Dali Interface IP 65 Gear Box



Photometric Data

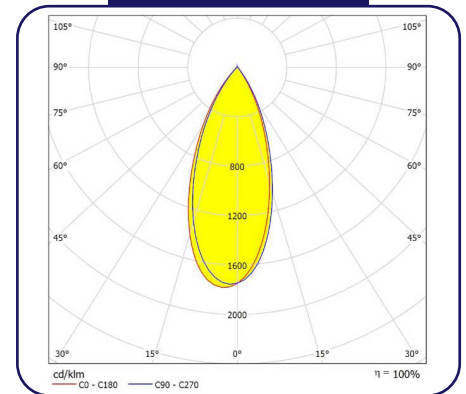

Drawing

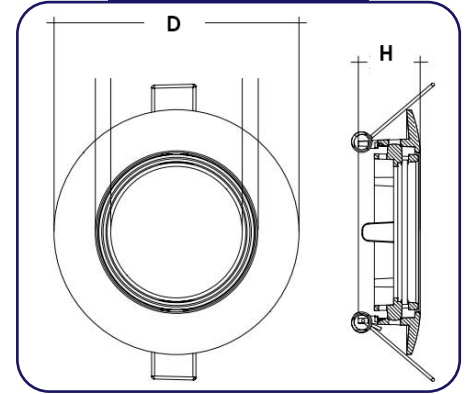

Model	Power	Size (D x H)	Lumen	Voltage	CCT	Beam Angle
NLC DL-02	6W	90 x 75 mm	600 LM	220-240V/50/60Hz	3000K	24°
	9W		900 LM			
	12W		1200 LM	110-277V/ 50/60Hz	4000K	36°



Adjustable



IP 65

Environment friendly product that is free of any hazardous materials

